

# Installation Guide

---

## N5101A Baseband Studio PCI Card

### Overview

This guide provides instructions on how to install the N5101A Baseband Studio PCI card in a PC. The PCI card is installed in a PC and is used with a signal source (or an N5515C wireless communications test set) to run Agilent software applications. This process comprises the following steps:

1. Verify that the hardware you received is correct, and note the license and serial number of each Baseband Studio PCI card (see [page 2](#)).
2. Ensure that your PC and signal source meet the basic installation requirements (see [page 4](#) and [page 5](#)).
3. Install the PCI card hardware (for the internal PCI card hardware, see [page 6](#); for external cabling, see [page 8](#)).
4. Install the Baseband Studio PCI card driver (see [page 9](#)).

After the PCI card installation is complete, the procedure directs you to the software installation guide for instructions on installing application software used with the PCI card (see [page 9](#)).

This document also provides troubleshooting tips (see [page 13](#)), application-specific cabling information (see [page 14](#)), Agilent assistance information (see [page 15](#)), and a list of additional PCI card-related documentation (see [page 16](#)).

---

**NOTE** The Baseband Studio PCI card shown in this document reflects the current PCI card that is being shipped. Older versions of the PCI card appear considerably different. However, all connectors are located in the same location as the board shown in this document.

---

---

**NOTE** A declaration of conformity is on file for the N5101A Baseband Studio PCI card and is available upon request.

---



N5101-90001

**Agilent Part Number: N5101-90001**

**Printed in USA January 2005**

**© Agilent Technologies, Inc. 2003 – 2005**

# Checking the Shipment

## Hardware

For each N5101A Baseband Studio PCI card purchased, you should receive the following items:

**Table 1** PCI Card Parts List



<b>1</b>	N5101A Baseband Studio PCI Card	<b>5</b>	Digital Bus Cable (P/N N5101-60003)
<b>2</b>	Installation Guide (P/N N5101-90001) (This manual. Formerly the Quick Start Guide.)	<b>6</b>	Loopback Fixture (P/N E4400-63583) (For troubleshooting)
<b>3</b>	GPIO Bracket (P/N N5101-60006) (Replaceable Parts of GPIO Bracket: - SMB-to-MCX Cable: P/N 8121-0655 - Ribbon Cable Assembly: P/N N5101-60004)	<b>7</b>	PCI card ISA Retainer & Screws Retainer: P/N 1400-3295 Screws: P/N 0624-0858 (2 each)
<b>4</b>	SMB to SMB Cables (P/N 8120-5020) (2 each) (For installation of two PCI cards)	<b>8</b>	Foam Pad (P/N N5101-20005) (For installation of two PCI cards)

**Note:** Although the Baseband Studio CD (P/N N5101-90002) is no longer shipped with the product, this installation guide provides instructions and information for downloading the software that the CD provided in case you no longer have the documentation that accompanied the CD.

# Entitlement Certificate

Each software application purchase includes one entitlement certificate. Software applications require a license file to be fully functional. The entitlement certificate shipped with your application purchase lists the products purchased, and has two of the four numbers required to obtain the license file.

Applications are licensed to a specific PCI card; you may license more than one application to a single PCI card. The N5101A Baseband Studio PCI card has the other two numbers needed to obtain the license file.

The license redemption process is described later in the installation procedure.

From the PCI card, you will need the following numbers. It is important to record and save these numbers now to avoid the need to remove your PCI card from the computer later in the installation procedure.

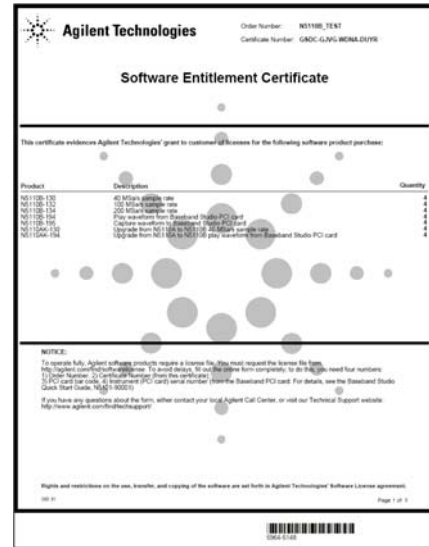

- PCI Card Bar Code License Number**

A bar code label that displays this license number is affixed to the PCI card as shown below.

Record the license number here: \_\_\_\_\_

- Instrument (Model) Serial Number**

A label that displays the serial number is affixed to the reverse side of the PCI card as shown below. The serial number is also displayed on a sticker affixed to the end of the box in which the card is packaged.

Record the serial number here: \_\_\_\_\_

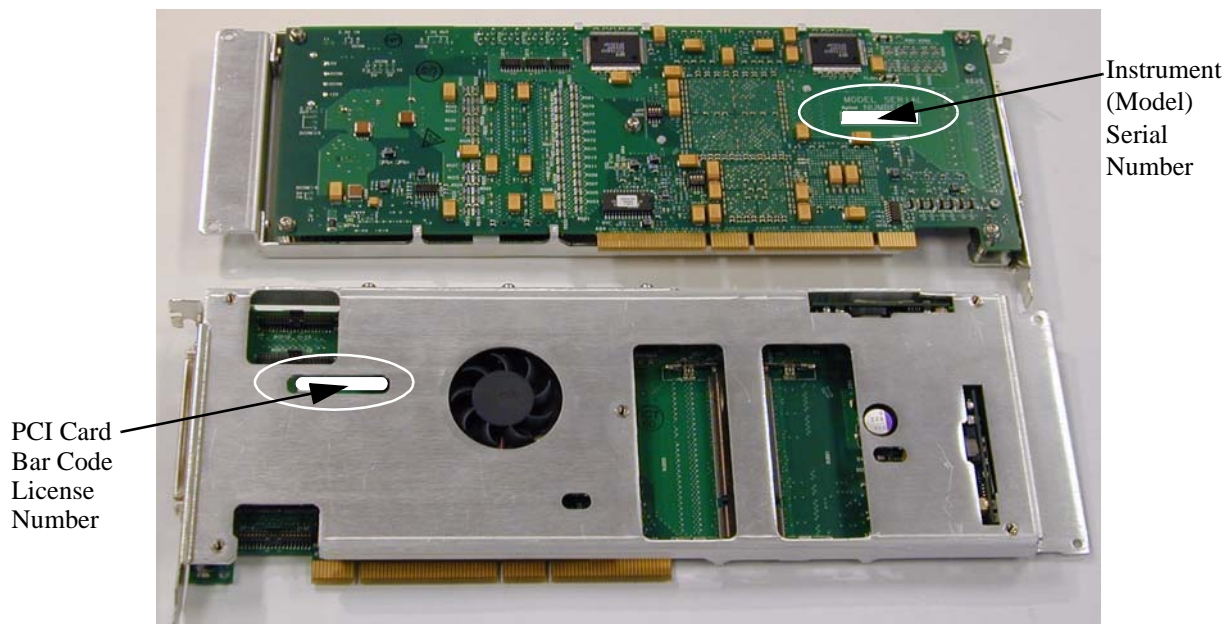

# System Requirements

## PC Requirements

### Requirements for all applications:

- You must be able to log on to your PC using an account with administrative privileges.
- The PC and all signal sources *must* be connected via LAN or GPIB.
- Available PCI slot(s) must meet the 2.2 PCI/ISA (or later) specifications (see the bottom of [page 13](#)).
- Not all computer cases are PCI or ISA compliant. PCI compliant computer cases accommodate the N5101A PCI card with the metal extender, thus enabling both ends to be restrained. For ISA compliant computer cases, an ISA retainer (included) must be attached to the N5101A PCI card metal extender to enable the card to fit into the ISA slots. To avoid reliability issues, the N5101A PCI card must be restrained on both ends. Refer to [page 6](#) for installation instructions.

### Application-specific requirements:

**Table 2 N5110A Baseband Studio for Waveform Streaming**

	Streaming Rate		
	Slow ( $\leq 5$ MSa/s)	Medium ( $\leq 20$ MSa/s)	Fast (40 MSa/s)
<b>Processor</b>	Pentium <sup>®</sup> 4, 2 GHz or greater	Pentium 4, 2 GHz or greater	Pentium 4, 2 GHz or greater
<b>Front Side Bus</b>	400 MHz	533 MHz	533 MHz
<b>Memory (Size, Type)</b>	512 MB, PC2100	1 GB, PC2700	2 GB, PC2700
<b>Available PCI Slots</b>	1: 32 bit/33 MHz and 1 additional PCI slot opening	1: 64 bit/66 MHz and 1 additional PCI slot opening	1: 64 bit/66 MHz or 1: 64 bit/133 MHz <sup>a</sup> and 1 additional PCI slot opening
<b>HDD Controller</b>	Generic IDE	Ultra 160 SCSI RAID Controller	Ultra 320 SCSI RAID Controller
<b>Hard Disks</b>	1: Ultra ATA (7200 RPM)	2: Ultra 160 SCSI (10K RPM)	5: Ultra 320 SCSI (15K RPM)
<b>HDD Configuration</b>	Single Drive with OS + Data	Dual Drive with OS + Data	Dedicated OS Drive, Data on RAID
<b>Operating System</b>	Windows <sup>®</sup> 2000 Professional, SP 3	Windows 2000 Professional, SP 3	Windows 2000 Professional, SP 3
<b>Example</b>	HP XW4100	HP XW8000	HP XW8000 w/add-on HDDs

a. Required for the RAID Controller

**Table 3 N5110B Baseband Studio for Waveform Capture and Playback**

<b>Processor</b>	Pentium III, 800 MHz or greater
<b>Memory (RAM)</b>	256 MB minimum
<b>Free Disk Space</b>	200 MB minimum
<b>Available PCI Slots</b>	One 32 bit/33 MHz and one additional PCI slot opening
<b>Operating System</b>	Windows XP Professional, SP 1 or greater -or- Windows 2000 Professional, SP 3 or greater

**Table 4 N5115A Baseband Studio for Fading**

<b>Processor</b>	Pentium III, 600 MHz or greater
<b>Memory (RAM)</b>	256 MB minimum
<b>Free Disk Space</b>	145 MB minimum
<b>Available PCI Slots</b>	Single-Channel Configuration: One 32 bit/33 MHz and one additional PCI slot opening Dual-Channel Configuration: Two 32 bit/33 MHz and two additional PCI slot openings
<b>Operating System</b>	Windows XP Professional, SP 1 or greater -or- Windows 2000 Professional, SP 3 or greater

## Signal Source Requirements

The PC and signal sources *must* be connected via LAN or GPIB.

**Table 5 Requirements for Signal Sources**

Application	Source Model	Source Firmware Revision	Source Options	Interface
<b>N5110B Baseband Studio for waveform capture and playback</b>	E8267D	C.04.04	601 or 602	LAN or GPIB
	E8767C	C.03.78 or later	602	LAN or GPIB
	E4438C	C.03.74 or later	601 or 602	LAN or GPIB
<b>N5110A Baseband Studio for waveform streaming</b>	E8267C	C.03.31 or later	602	LAN or GPIB
	E4438C	C.03.30 or later	601 or 602	LAN or GPIB
<b>N5115A Baseband Studio for fading</b>	E4438C	C.03.40 or later	601 or 602	LAN or GPIB
	E5515C	E6702B:B.03.00 or later, E6703C:C.01.00 or later, or E6785C: C.01.00 or later	003 E5515CU Option 504 E5515CU Option 187 <sup>a</sup>	GPIB only

a. E5515CU Option 187 required for W-CDMA usage only.

# Installing the Hardware

## PC Hardware and Internal Cables

### All Applications:

Power down the PC and disconnect the AC power cable.

Before you install the Baseband Studio PCI card, be sure to note the bar code license number and the model serial number on the card (described on [page 3](#)).

---

**NOTE** The N5101A PCI card is a 64-bit card. If you are using the streaming application from a hard disk a 64-bit slot is required. Otherwise, a 32-bit slot may be used without loss of functionality.

---

### Single-card Installation:

#### Internal cabling:

1. Connect the GPIO bracket ribbon cable to J3 on the PCI card. The remaining cables can be connected, as shown, either before or after you install the PCI card in the computer.

Number on GPIO Bracket	PCI Card Connector
4	J10
5	J11
6	J12
7	J3
8	J13

**Caution:** Use standard precautions to protect against electrostatic discharge when handling the PCI card.

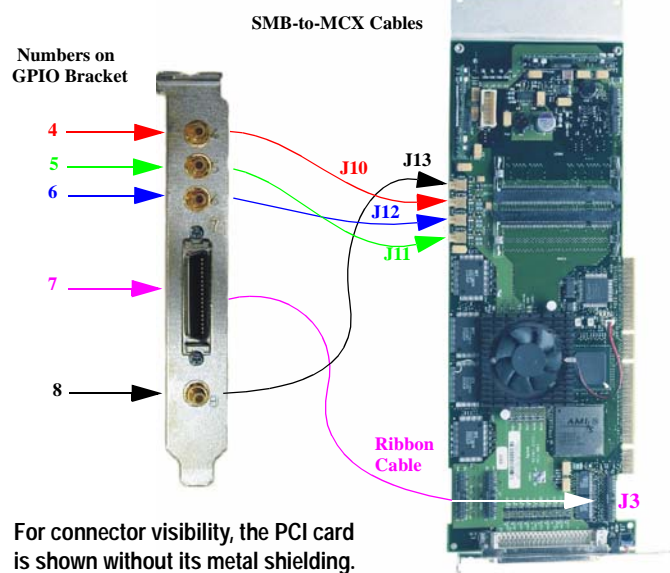

2. For PCI compliant computer cases, install the N5101A PCI card and GPIO bracket using two PCI slots in the PC. Refer to the PC's documentation for specific installation instructions.

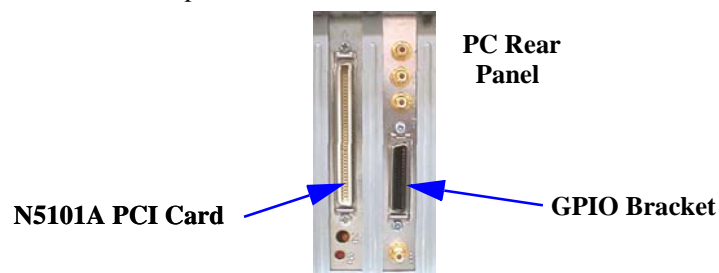

3. Ensure that the metal shielding bracket of the PCI card slips into the PCI slot at the front of the case. If it does not fit, refer to step 4.

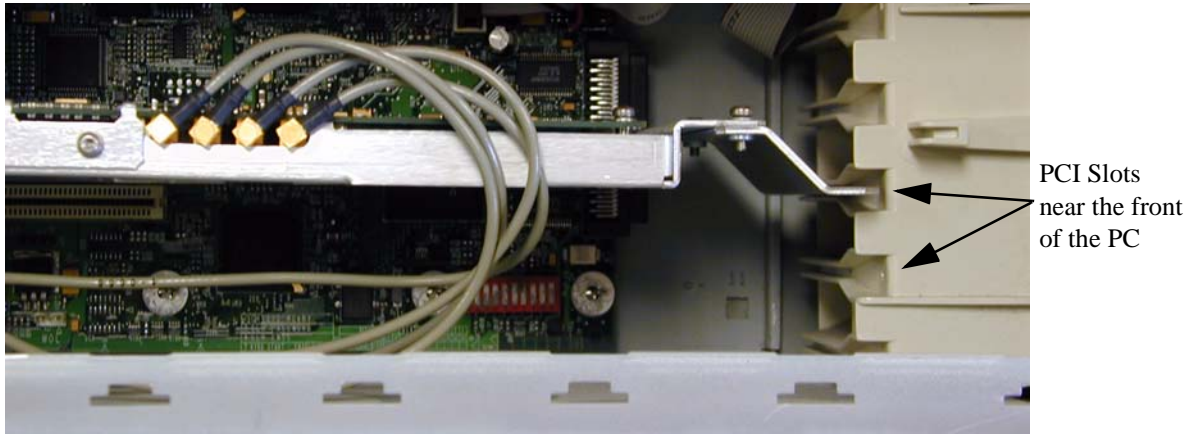

4. For ISA-compliant computer cases, attach the metal extender bracket to the PCI card shielding using the two screws provided. See the illustration below. The extender will slip into the guides at the front of the ISA-compliant PC case as shown in the illustration above.

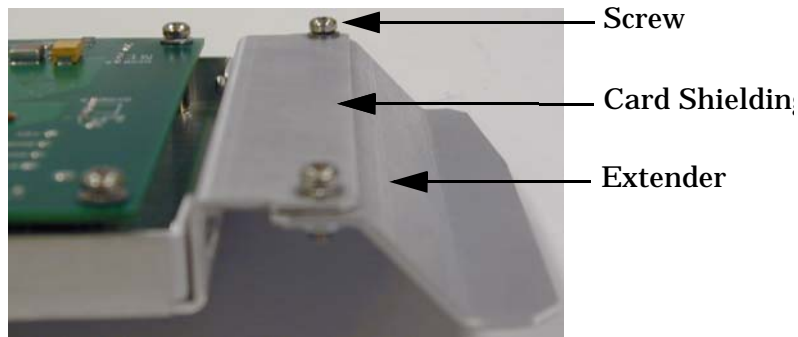

5. Secure the rear of the PCI board (the end with the digital bus connector) to the PC chassis with a mounting screw.
6. Reconnect the AC power cable.
7. If the LAN/GPIB was disconnected, reconnect it.



## Two-card Installation:

Before you install the PCI cards in the PC for the dual-channel fading application, attach the foam pads approximately 1 inch from the top of the PCI card as shown in Figure A of the following illustration.

If the PCI/ISA slots are such that the two cards must be installed side-by-side (as in Figure B), you may need to route one or both of the ribbon cables under the PCI cards to connect them. This does not damage the cables.

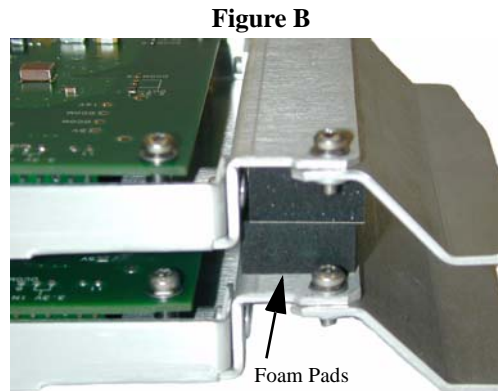
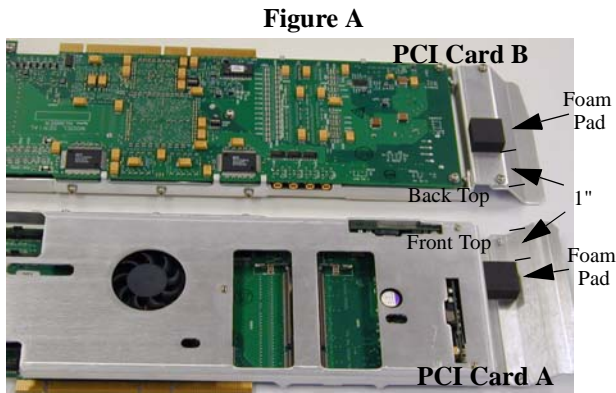

## External Cables

Install the digital bus cable for all applications.

1. Inspect the digital bus cable and connectors to ensure that they are clean.
2. Connect a digital bus cable between each N5101A Baseband Studio PCI card and a source (or N5102A Baseband Studio digital signal interface module), connecting the end of the cable with the EMI suppressor to the source.

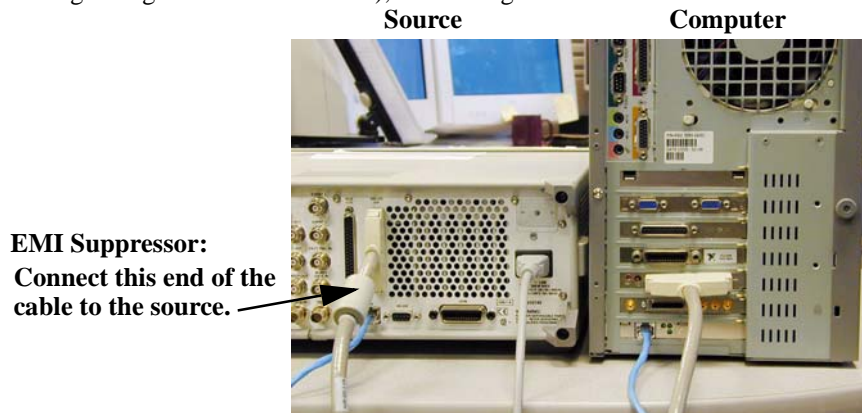

**NOTE** The digital bus cable connector has a release latch on each side. As you make a connection, you must simultaneously squeeze these release latches (see the illustration below); the connector should snap into place. A securely connected cable does not come loose when gently pulled.



To disconnect the cable, squeeze the release latches as you remove the connector.



---

## Installing the Software

- If you received a CD-ROM with your N5101A PCI card, follow the instructions in “[Installing the Baseband Studio Software using the CD-ROM](#)” on page 10 to install your software.
- If you do not have a PCI card CD-ROM or if you want to install the most recent Baseband Studio application version, follow the instructions in this section to install your software.

### PCI Card Driver

1. Go to the Agilent Technologies web site: <http://www.agilent.com/find/basebandstudio>.
2. Click the **N5101A** product link.
3. On the N5101A Baseband Studio PCI Card page, click the **Baseband Studio PCI Card Driver** link and follow the download instructions.

### Application Software

To install the Baseband Studio application software, refer to the Agilent Technologies Software (for Baseband Studio and Signal Studio) Installation Guide (part number E4400-90559). This document leads you through installing the Baseband Studio software applications. To access this document:

1. Go to the Agilent Technologies web site: <http://www.agilent.com/find/basebandstudio>
2. Click the product link for the Baseband Studio application that you wish to download.
3. On the Baseband Studio application page, click the link for the software installation guide and follow the download instructions. Print this document.

---

## Installing the Baseband Studio Software using the CD-ROM

The Baseband Studio software CD-ROM is no longer shipped with the N5101A Baseband Studio PCI card. The most recent versions of the Baseband Studio applications are only available by downloading them from the Agilent web site.

If you have the Baseband Studio software CD-ROM, you can install the older Baseband Studio versions of fading and waveform streaming without downloading them from the Agilent web site. This section contains the instructions for installing these older applications using the CD-ROM.

### Licensing the Software

Baseband Studio applications require a license file to be fully functional. You will need to provide the following information to obtain the license file.

<b>From the entitlement certificate:</b> <ul style="list-style-type: none"><li>• Order Number</li><li>• Certificate Number</li></ul>	<b>From the N5101A PCI card<sup>a</sup>:</b> <ul style="list-style-type: none"><li>• PCI card Bar Code License Number</li><li>• Instrument (Model) Serial Number (<i>optional</i>)</li></ul>
--	--

- a. Applications are licensed to a specific PCI card; you may license more than one application to a given PCI card. Refer to [page 3](#) for the location of the bar code license number and the serial number.
1. Go to <http://www.agilent.com/find/softwarelicense> and follow the software license redemption process to obtain your license file. The license file will be e-mailed to you promptly.
  2. Copy the file into the following program directory: `C:\Program Files\Agilent\Baseband Studio\LicenseFiles`
  3. Make a back-up copy of the license file and store it in a safe place. You will need this back-up file if the license file is lost or erased.

### Installing the Software

1. If not already done, reconnect the AC power cable and turn on the PC.  
The PC's Found New Hardware wizard prompts you for a suitable driver, which is located on the Baseband Studio Software CD.
2. Insert the software CD into your PC's CD-ROM drive.
3. In the Found New Hardware wizard, click **Next**.  
Follow the instructions in this wizard, and accept the driver `N5101A.inf`. If the wizard does not find the driver automatically, browse the `driver` folder on the CD and select it.
4. Locate `AgilentBasebandStudioInstall.exe` on the CD and run it. The Agilent Baseband Studio-InstallShield Wizard appears; click **Next**, and follow the setup instructions. The Baseband Studio PCI card software installs.
5. If not already done, configure Agilent IO Libraries to include the signal source.  
See "[Configuring the Vector Signal Generator Using the LAN Interface](#)" on [page 11](#) for an example using the LAN interface. Signal sources connected using GPIB are configured in a similar manner.
6. Run the Baseband Studio IO Config utility: This utility provides the system configuration and verification required by Baseband Studio applications.  
**Start > Programs > Agilent Baseband Studio > Baseband Studio IO Config > IO Config**  
Follow the on-screen instructions. For details on using this utility, refer to the utility's help. Run this utility whenever you make a change that could affect the configuration of the Baseband Studio PCI cards and instruments.

7. After the Baseband Studio software is installed and configured, copy the license file into the directory:  
*C:\Program Files\Agilent\Baseband Studio\LicenseFiles*

For details on obtaining a license file, see [“Licensing the Software” on page 10](#); for details on using a license file with an application, refer to the Baseband Studio IO Config help, and the help in the individual applications.

8. Run the Baseband Studio applications (found in the *Agilent Baseband Studio* directory).

When you initially run a Baseband Studio application, it looks for the required license file.

## Configuring the Vector Signal Generator Using the LAN Interface

### Direct LAN Connection between PC and Vector Signal Generator:

A direct connection between the PC and a vector signal generator requires a LAN crossover cable. In this case, *first* do the following:

1. Select **Start > Settings > Network & Dialup Connections**.
2. Right-click on the Local Area Connections icon, and select **Properties**.
3. Select **Internet Protocol** and click **Properties**.
4. Click **Use the following IP address**, and enter the vector signal generator’s IP address (adding 1 to the last digit), subnet mask, and default gateway.
5. Click **OK, OK**.

## All Configurations:

1. Run the Agilent IO Libraries IO Config program: **Start > Programs > Agilent IO Libraries > IO Config**
2. If no interfaces are configured, click **Auto Config**.
3. Select **TCPIP LAN Client (LAN Instrument)**.
4. Select **TCPIP0** and click **Edit**.
5. Click **Edit VISA**.
6. Click **Add Device**.
7. Enter the signal source's IP address; a device name is not required.
8. Click **OK, OK, OK, OK** to close IO Config windows.
9. As verification, run the Agilent IO Libraries Visa assistant program: **Start > Programs > Agilent IO Libraries > Visa Assistant**.
10. In the left pane, select the instrument you just configured; in the right pane, click the **Formatted I/O** tab.
11. Click the **SCPI Instr. Lang.** radio button, then the **\*IDN?** button. Your instrument's model and serial number should appear.
12. Select **File > Exit**.

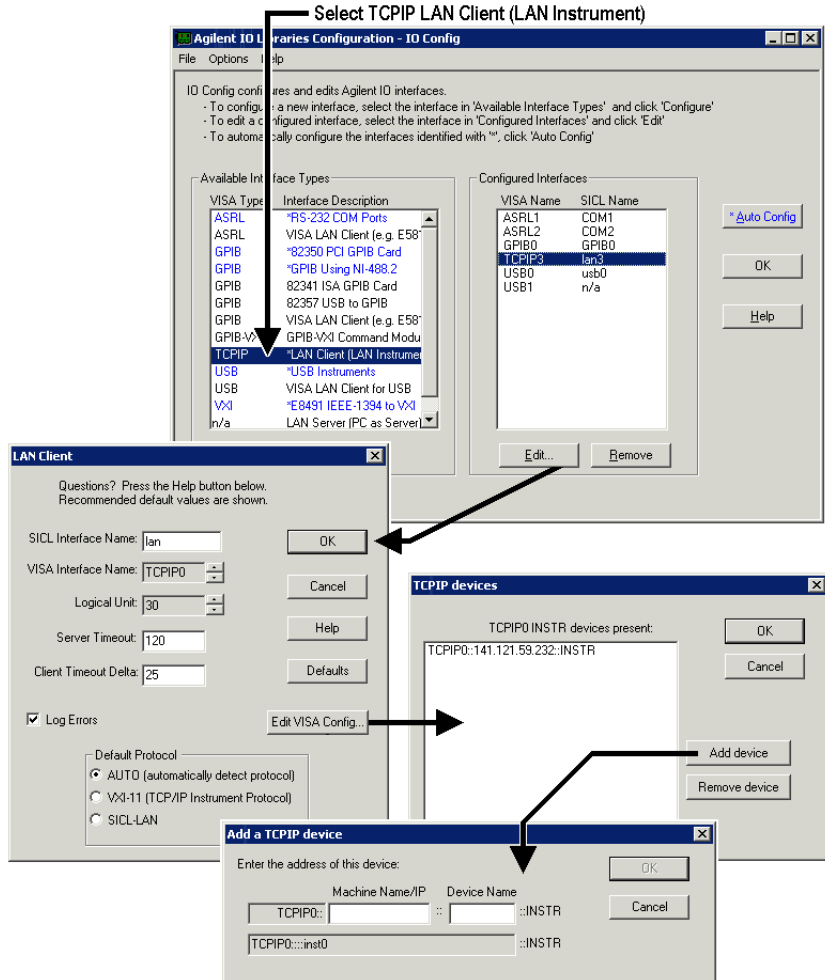

---

## Troubleshooting

### The Found New Hardware wizard is not displayed

If an N5101A Baseband Studio PCI card was previously installed, you may see a slightly different dialog from the New Hardware Detected wizard. If this happens, select the file *N5101A.sys* from the *driver* directory on the Baseband Studio CD, rather than the *N5101A.inf* file.

### No Prompt for the N5101A Baseband Studio PCI card driver

If you are not prompted for the N5101A Baseband Studio card driver, turn off the PC and ensure that the PCI card is securely seated in its slot. Reboot the PC, and log on using an account with administrative privileges.

### N5101A Baseband Studio PCI card does not appear in the IO Config utility Select an N5101A List

Ensure that all N5101A Baseband Studio PCI cards are installed correctly:

1. On the PC desktop, right-click the My Computer icon.
2. Select **Properties**.
3. Click the **Hardware** tab.
4. Click **Device Manager**.  
Under Agilent Technologies Test & Measurement Devices, you should see at least one Agilent N5101A listed.
5. Right-click an Agilent Technologies N5101A icon and select **Properties**.

In the Device status area, you should see the message, "This device is working properly." If not, the N5101A Baseband Studio PCI card is probably not seated properly in the PC.

### N5101A PCI Card-PC Installation Compatibility Issues

- **PCI Long Card**

Some PCs will have front card guides in the plane of the N5101A PCB which will support the front edge of the metal extension plate on the N5101A card. These front card guide slots will be about 305 mm (12 inches) from the rear card mounting surface and in line with the PCI connector. The N5101A PCB with the installed front metal plate is compliant with the PCI long card specification. The overall card length is 312 mm (12.283 inches).

- **ISA Long Card**

Some PCs will have ISA-compliant front card guides. These ISA front card guide slots will be about 335 mm (13 inches) from the rear card mounting surface and offset from the plane of the N5101A PCB and PCI connector by 14.27 mm (0.562 inches). An ISA retainer (an adaptor with two mounting screws) must be installed onto the N5101A metal extension plate to support the front of the card.

- **PC Slot Too Short for N5101A PCI Card**

The N5101A front metal extension plate may be removed. If the PC slots are still too short, a PC with PCI or ISA long card compliant slots is recommended.

## Application-Specific Cabling

### N5110A Baseband Studio for Waveform Streaming/N5110B Baseband Studio for Waveform Capture and Playback, External Triggering

The GPIO bracket accepts an input trigger (Start), and provides two output markers (Ready and Underflow). For details, refer to the application's help.

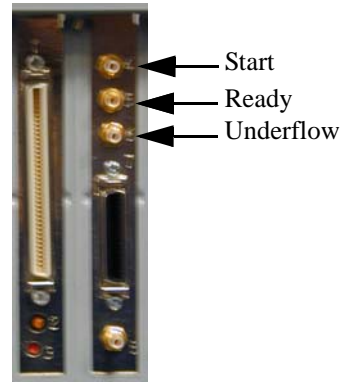

### N5115A Baseband Studio for Fading, Dual Channel

#### Recommended Setup:

Connect three SMB-to-SMB cables between the two GPIO brackets as shown. The cables are connected as follows:

Connector on Master GPIO Bracket	Connect to...	GPIO Bracket Connector
4		Slave 8
5		Master 8
6		Slave 5

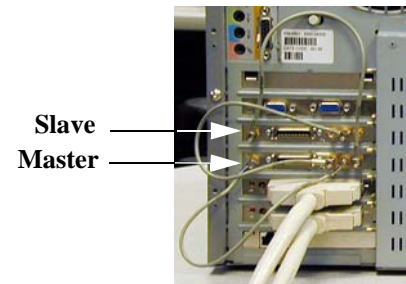

#### Alternate Setup:

If you are using two PCI cards for dual-channel fading and your PC has fewer than four open PCI slots, you can connect the PCI cards internally using three MCX-to-MCX cables (Agilent part number 8121-0620). These cables are not provided with the PCI card. The cables have MCX (male) connectors on both ends. They are connected as shown below:

From Master PCI Card	Connect to...	PCI Card
J13		Master J11
J10		Slave J13
J12		Slave J11

**Note:** Cabling is not connected to connectors J10 and J12 on the Slave PCI card.

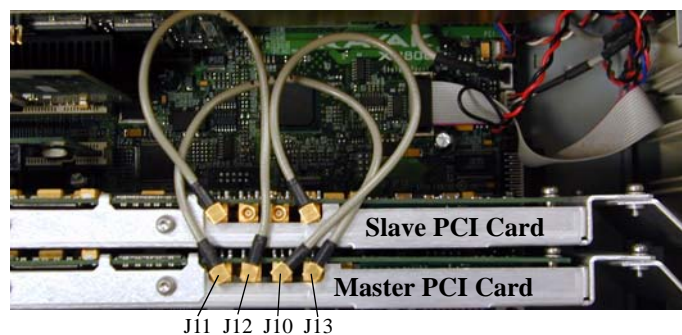



---

## Getting Assistance from Agilent

Your local Agilent office can help you with your test and measurement needs. The following Internet URL provides the information you need to contact your local Agilent office: <http://www.agilent.com/find/assist>

If you do not have access to the Internet, please contact your field engineer.

---

**NOTE** In any correspondence or telephone conversation, refer to the product by its model number and full serial number. With this information, the Agilent representative can determine whether your product is still within its warranty period.

---

---

## Additional PCI Card-Related Documentation

The following list of PCI card-related documentation is available from the Agilent web site (<http://www.agilent.com>).

The easiest method of finding this documentation is using the Agilent web site search tool to search for the document part number.

- Agilent N5101A Baseband Studio PCI Card Memory Upgrade Installation Note  
Agilent part number: N5101-90003
- Agilent Technologies Software Installation Guide for Baseband Studio and Signal Studio  
Agilent part number: E4400-90559
- Agilent Technologies E5515C Fading Solution Application Guide  
Agilent part number: 1000-1894  
<http://cp.literature.agilent.com/litweb/pdf/1000-1894.pdf>